



Scanning Stage SCAN IM 130 × 100

for Zeiss Axiovert 35 / 100 / 135 / 135 M / 200 M / 200 MAT / 200 M MAT

Specifications

Travel range	max. 130 × 100 mm
Travel speed	max. 60 mm/s (with 1 mm ball screw pitch)
Repeatability	< 1 µm ¹ (bi-directional)
Accuracy	±3 µm ¹
Resolution	0.01 µm (smallest step size)
Orthogonality	< 10 arcsec
Motor type	2-phase stepper motor
Limit switches	mechanical limit switches
Material / surface	aluminium / anodic coating, black lacquered
Weight	approx. 4.3 kg

Order Information

Order No.: 00-24-546-0000
(1 mm ball screw pitch)

Product Features

- ▶ exchangeable stage inserts for different kinds of applications
- ▶ continuously adjustable travel range limitation for individual adjustment of travel range for different applications
- ▶ integrated electronic stage identification device ETS for automatic identification of the scanning stage and parametrization of the controller
- ▶ **5 years guarantee**, if the scanning stage is operated in the system with the Märzhäuser TANGO controller

Dimensions

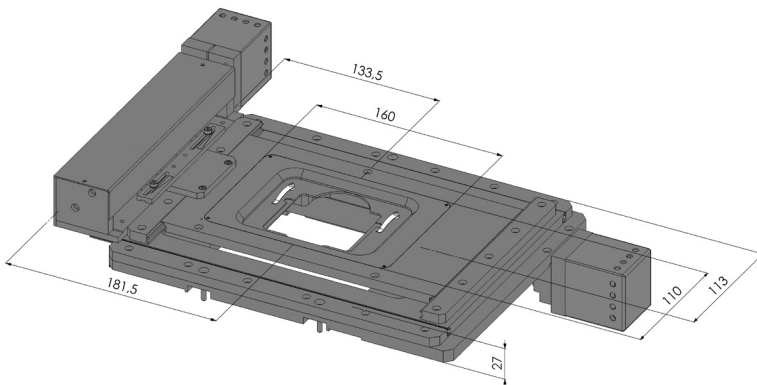

Accessories

Stage insert for 1 slide 3" × 1"
(included in delivery)
Order No.: 00-29-411-8010

Piezo Z-stage
Order No.: 00-55-550-0800

For various stage inserts with dimensions
160 × 110 × 8 mm and further accessories
please visit: www.marzhauser.com